

Drum-Dryer-5

The Drum-Dryer-5 is a modular roll-to-roll drying unit to be combined with our padding and washing units into a complete production line.

The Drum-Dryer-5 unit is developed as a universal contact dryer in various applications. Textile washing and drying are automatically synchronised to a one step process. The functional principle of contact heating can also be used in curing applications of pigment prints as well as heat fixation of disperse dyes onto polyester.

The DD-5 is equipped with electrically heated, thick walled aluminium drums, guaranteeing an even temperature in the full width of the drum and a quick heat transfer to the textile. The fabric in the DD-5 touches the drums one-sided only, so undesirable ironing effects are avoided.

Since electricity might be limited a gas or oil burner is available as an option to replace the electric heating system. A combination of electrical heated drums and others on gas or oil heating can be made.

The maintenance-free chains drive the drums. A fabric bar can be attached to the chains left and right which greatly simplifies the feed-in handling of cloth into the unit.

All modules required for the proper functioning of the Drum-Dryer are integrated in the device. The drying/fixation chamber is equipped with an integrated exhaust to remove hazardous solvents and moisture, which evaporate easily at high temperatures, thereby keeping the working environment clean. A heat recovery system is used to pre-heat the fresh air, thereby saving on energy costs.

With temperatures between 50 and 200°C (150 °C when on burners) and dwell times from 15 seconds till several minutes the DD-5 is suitable for a wide range of drying, curing and fixation applications.

The DD-5 series is available in our standard widths of 1.85, 2.50 and 3.40 meter. The construction is made of 304 stainless steel and teflon coated aluminium drums.

The Drum-Dryer-5 is **CE** marked.

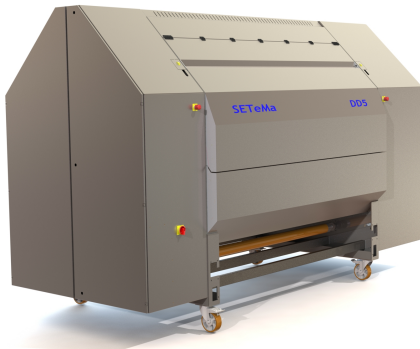

- universal contact dryer
- curing unit for pigment prints
- complete autonomous heat fixation for disperse direct and disperse transfer/sublimation dyes
- maintains the textile structure due to the pressure-free heat fixation
- integrated exhaust
- efficient heat transfer by heated, aluminium drums
- easy to operate
- easy to maintain
- available in 1.85, 2.50 and 3.40 meter width

options:

- custom power / frequency
- gas/oil heating system

Drum-Dryer-5 technical specifications

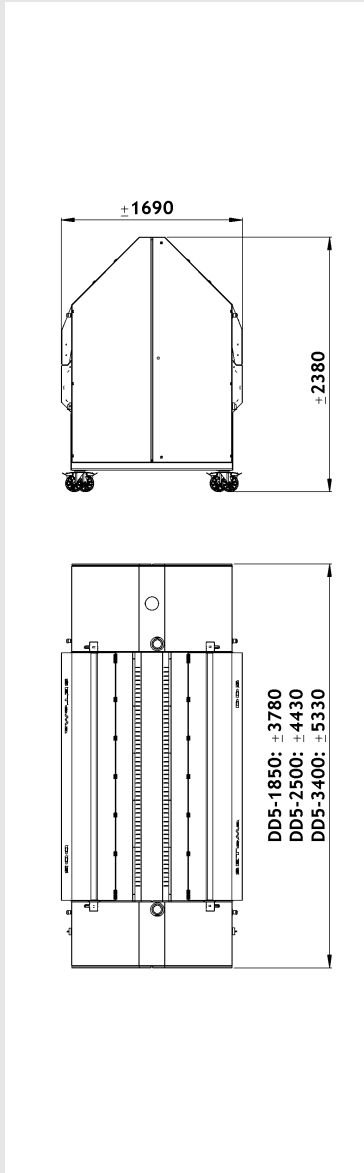

Type, capacity		DD5			
Fabric length inside Drum-Dryer		12			[m]
Fabric length in contact with drum		3.6			[m]
Production capacity	150 sec. contact time	86.4			[m/h]
	60 sec. contact time	216			[m/h]
	30 sec. contact time	432			[m/h]
Temperature range	Drum temperature	50 - 200			[°C]
Fixation	Typical fixation temperature	175 - 200			[°C]
Pigment curing	Typical curing temperature	140 - 150			[°C]
Drying	Typical drying temperature	90 - 120			[°C]
Evaporation capacity		48 - 75			[kg/h]
Maximum drying capacity	36 g/m ² wet pick-up	~ 700			[m/h]
	72 g/m ² wet pick-up	~ 350			[m/h]
Type, width		1850	2500	3400	
Fabric	maximum width	1.85	2.50	3.40	[m]
Fabric roll	maximum weight	60			[kg]
	maximum diameter	0.55			[m]
Speed min. - max.	hour based	30 - 390*/60 - 780**			[m/h]
	minute based	0.5 - 6.5*/1-13**			[m/min]
Exhaust fan	flow	up to 1500			[m ³]
Weights		2200	2400	2700	[kg]
Required Connections		1850	2500	3400	
	power voltage	N + 3 x 230Y/400Δ			[VAC]
	power current	63 + 63			[A]
	DD-5 heater, power	52	64	80	[kW]

* gearbox ratio 60

** gearbox ratio 30